

INSTINCT®

ideal
HEATING



YEARS
OF EXCELLENCE

Hot Water Cylinder Range



www.instinctproducts.co.uk
www.idealheating.com

Instinct Hot Water Cylinder Range by Ideal – works hand in hand with your boiler

Ideal's Instinct hot water cylinders for your home's central heating system are built to the highest standards. Combining quality, durability and efficiency, our hot water cylinders have been designed to work in harmony with your boiler for fantastic results.

Available in sizes of up to 300 litres, Instinct's hot water cylinders can help keep your home wrapped in comfort all year long – whatever your central heating needs. We have five models in the range, all with a 2 year parts and labour warranty.

25 year vessel warranty

Less space required – no need for a water storage tank in the loft

Available in sizes up-to 300 litres

Corrugated heating coil

Manufactured from duplex stainless steel

Manufactured in the UK

Instinct's hot water cylinders work with your boiler to provide your home with the heat and warmth you need, perfect for homes that have a high demand for hot water.

Instinct hot water cylinders – a high quality addition to your central heating system.



Contents

We've got you covered

In partnership with Ideal, we believe in quality manufacturing and pride ourselves on providing a wide range of heating solutions designed and manufactured in the UK.

Ideal's Instinct hot water cylinder range benefits from proven technologies at a competitive price and guarantees reliability with a 25 year warranty.

If you need technical advice or sales support, we have fully trained experts that can provide assistance. Whether it be a customer looking for technical information or you need support in placing your order, we're here to help.

Technical Help

T: 01482 498663

E: enquiries@idealheating.com

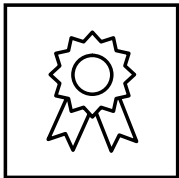

Quality Manufacturing



Manufactured in the UK

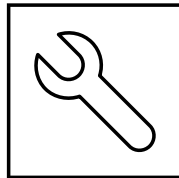

Expert Technical Support

Instinct Standard Cylinders

4

Standard Direct + Standard Indirect Cylinders 4

Technical Specification 5

Instinct Slimline Cylinders

6

Slimline Direct + Standard Indirect Cylinders 6

Technical Specification 7

Instinct Pre Plumbed System Ready Cylinders

8

new Indirect Pre Plumbed System Ready Cylinders 8

Technical Specification 9

Also available in the Instinct + Ideal range

10

Instinct² Combination Boiler 10

Ideal OpenTherm Wired Room Thermostat 11

Standard Direct + Standard Indirect Cylinders 120 150 170 200 250 + 300*

25

Year Guarantee†



Next day delivery available



Proven technologies and quality manufacturing at a competitive price



High corrosion resistant duplex stainless steel



Mains pressure hot water

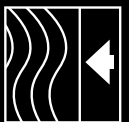

40mm insulation



Manufactured in the UK

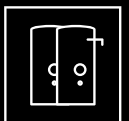

Direct + Indirect models available



Compression fittings included as standard

*300 available in Standard Indirect only

†Guarantees

25 Years on Vessel

2 Years on Parts

Standard

Technical Specification

Standard Direct

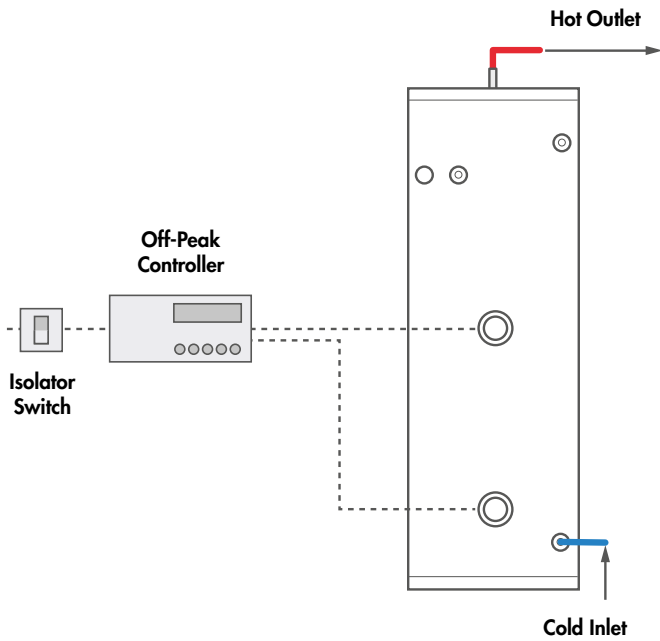

Standard Indirect

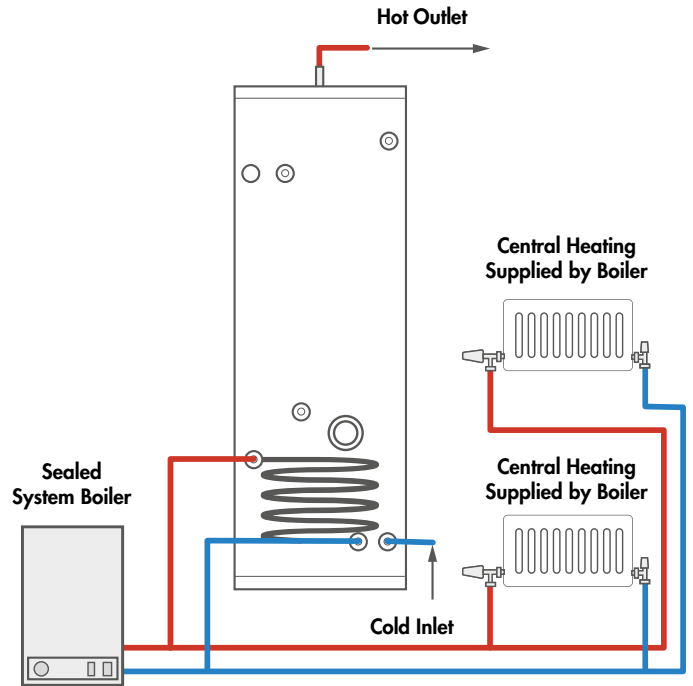

Standard Direct

	ErP Rating	Heat Loss (Watts)	Heat Loss (kWh/24h)	Capacity (Litres)	Height (mm)	Diameter (mm)
IDEINSDR120	C	43	1.03	118	832	530
IDEINSDR150	C	52	1.24	149	1012	530
IDEINSDR170	C	57	1.37	169	1131	530
IDEINSDR200	C	65	1.56	198	1305	530
IDEINSDR250	C	79	1.89	248	1603	530

Standard Indirect

	ErP Rating	Heat Loss (Watts)	Heat Loss (kWh/24h)	Capacity (Litres)	Height (mm)	Diameter (mm)
IDEINSIN120	B	43	1.03	118	832	530
IDEINSIN150	B	52	1.24	149	1012	530
IDEINSIN170	B	57	1.37	169	1131	530
IDEINSIN200	C	65	1.56	198	1305	530
IDEINSIN250	C	79	1.89	248	1603	530
IDEINSIN300	C	92	2.20	295	1895	530

Slimline Direct + Slimline Indirect Cylinders 120 150 180 + 210

25

Year Guarantee†



Next day delivery available



Proven technologies and quality manufacturing at a competitive price



High corrosion resistant duplex stainless steel



Mains pressure hot water



40mm insulation



Manufactured in the UK

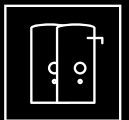

Direct + Indirect models available



Compression fittings included as standard

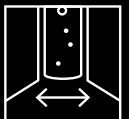

Reduced diameter of 475mm for smaller properties and space limitations

Slimline

†Guarantees

25 Years on Vessel

2 Years on Parts

Technical Specification

Slimline Direct

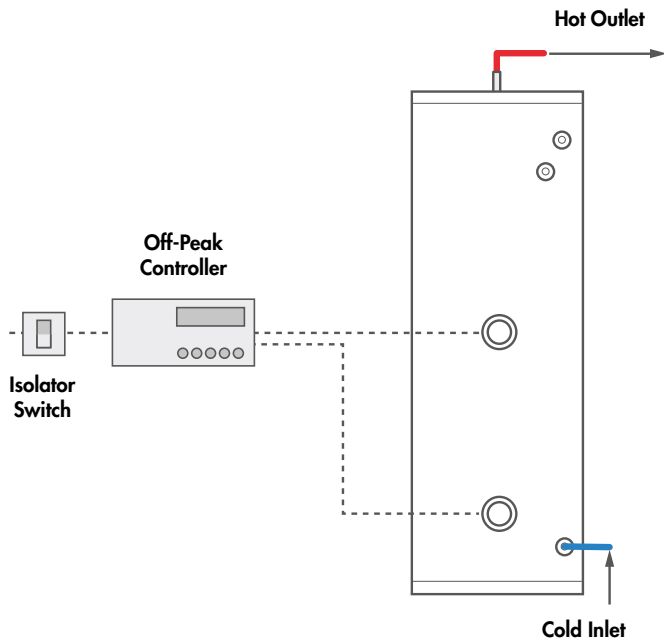

Slimline Indirect

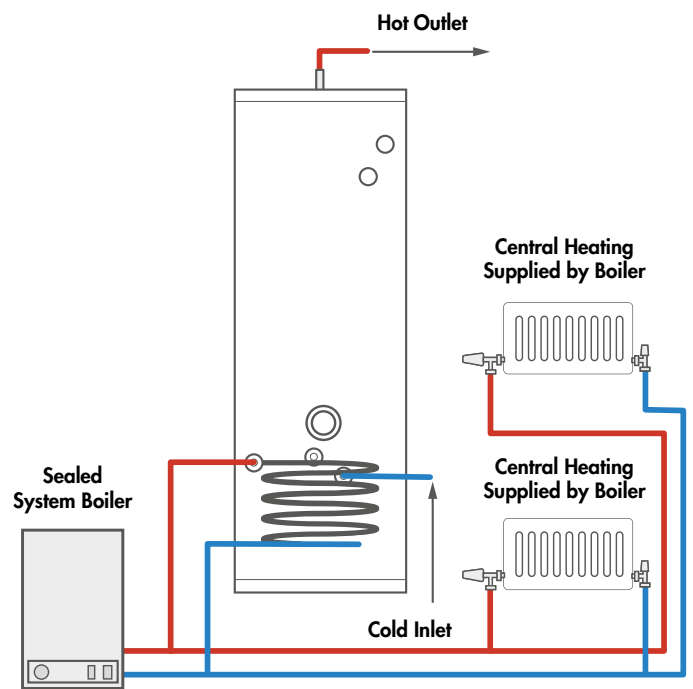

Slimline Direct

	ErP Rating	Heat Loss (Watts)	Heat Loss (kWh/24h)	Capacity (Litres)	Height (mm)	Diameter (mm)
IDEINSDR120SL	C	47	1.13	120	1248	475
IDEINSDR150SL	C	56	1.37	149	1519	475
IDEINSDR180SL	C	67	1.61	181	1791	475
IDEINSDR210SL	C	74	1.77	197	1963	475

Slimline Indirect

	ErP Rating	Heat Loss (Watts)	Heat Loss (kWh/24h)	Capacity (Litres)	Height (mm)	Diameter (mm)
IDEINSIN120SL	B	47	1.13	120	1248	475
IDEINSIN150SL	B	56	1.37	149	1519	475
IDEINSIN180SL	C	67	1.61	181	1791	475
IDEINSIN210SL	C	74	1.77	197	1963	475

new

Indirect Pre Plumbed System Ready Cylinders

120 150 170 200 250 + 300

25

Year Guarantee†



Next day delivery available



Proven technologies and
quality manufacturing at a
competitive price



High corrosion resistant
duplex stainless steel



Mains pressure hot water



Manufactured in the UK



High quality fittings



Straight pipework for
easy installation

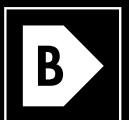

B ErP rating up to 170L model

†Guarantees

25 Years on Vessel **2** Years on Parts

Pre Plumbed System Ready

What are we doing?

We are pleased to announce the launch of the new Instinct Pre Plumbed System Ready range for cylinders. Available in sizes 120, 150, 170, 200, 250 + 300 litres.

Why are we doing this?

Competitors have developed pre-plumbed ranges that can compete in the lower end of the market therefore a System Ready cylinder based on the ES under Instinct brand to compete in this market was developed with a pipework layout to differentiate it from the current PRO PPSR.

Features + Benefits

Designed exclusively, maintaining the aesthetics and architecture of the current Instinct indirect range of cylinders

New pipe layout to suit smaller diameter cylinder to enable continuity of branding compared to PRO with wider diameter

Designed with standard plumbing parts for improved ease of installation, and installer familiarity, ensures easy on site installation

Specific designed System Ready for retrofit installations

Straight pipework to assist with insulating and simplicity

Consistent quality fittings with press fittings

Technical Specification

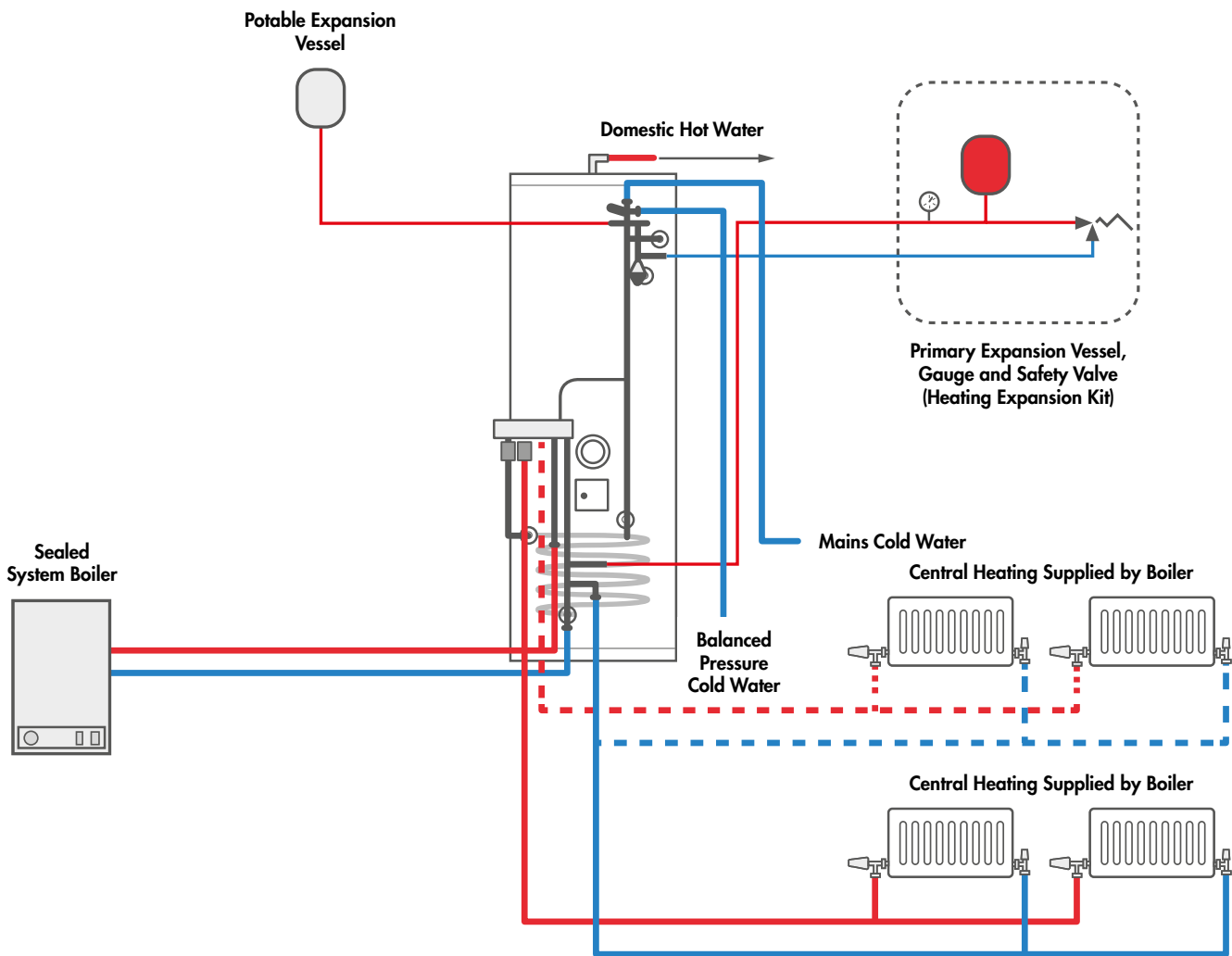

Indirect Pre Plumbed System Ready

	ErP Rating	Heat Loss (Watts)	Heat Loss (kWh/24h)	Capacity (Litres)	Height (mm)	Diameter (mm)
IDEINSIN120PPSR	B	43	1.03	118	832	530
IDEINSIN150PPSR	B	52	1.24	149	1012	530
IDEINSIN170PPSR	B	57	1.37	169	1131	530
IDEINSIN200PPSR	C	65	1.56	198	1305	530
IDEINSIN250PPSR	C	79	1.89	248	1603	530
IDEINSIN300PPSR	C	92	2.20	295	1895	530

Also available in the range – The Ideal Combo Instinct² Combination Boiler + Ideal OpenTherm Wired Room Thermostat

5

Year Guarantee†

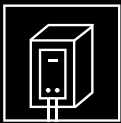

Compact cupboard fit

kg

Low fit weight



OpenTherm ready



Easy to read pressure gauge

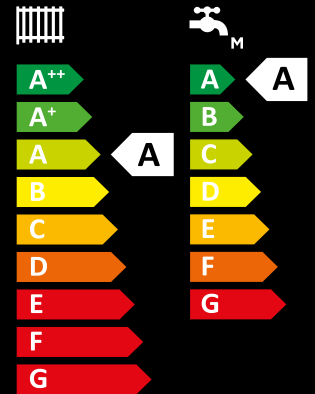

Manufactured in the UK



NOx class 6



Frost protection



Improved digital display

†Guarantees

5 Years on Boiler **2** Years on Thermostat

Instinct² Combination Boiler

Instinct² Combination Boiler

The Instinct² combination boiler is available in outputs of 24, 30 and 35 kW providing a cost effective heating solution for a range of domestic installations.

Complete with domestic hot water temperature controls including a switched preheat function, mechanical built-in timer and a digital operating status & diagnostic display, the Instinct² provides reliable control of the homes heating and hot water performance.

220481 – Ideal Instinct² 24 Combi Boiler

220482 – Ideal Instinct² 30 Combi Boiler

220483 – Ideal Instinct² 35 Combi Boiler

Dimensions – 700(h) x 395(w) x 285(d) mm

Features + Benefits

- Quick and easy to install
- Easy access to all components
- Tried and tested technology (including Grundfos pump)
- Fast fix flue turret connections
- Mechanical timer in-built as standard
- OpenTherm wiring for enhanced load compensation
- Pump/diverter valve exercise & anti-cycling functions
- Fast hot water response through DHW preheat
- Fully supported by Ideal Service Division

Technical Specification	Instinct ² 24	Instinct ² 30	Instinct ² 35
Weight (Packaged) (kg)	33.7	33.7	33.8
Max Installation Weight (kg)	29.9	29.9	30.0
CH Output (kW) Min/Max Mean 70°C	4.8 - 24.2	6.1 - 24.2	7.1 - 24.2
CH Output (kW) Min/Max Mean 40°C	5.1 - 25.6	6.4 - 25.6	7.5 - 25.6
DHW Output (kW) Max	24.2	30.3	35.3
DHW Flow Rate l/min. 35°C Rise	9.9	12.4	14.5
SEDBUK Rating (2005) %	91.0	91.1	91.0
SEDBUK Rating (2009/2012) %	89.0	89.0	88.9
NOx Classification	CLASS 6	CLASS 6	CLASS 6
Water Heating Efficiency Class	A	A	A
Max Horizontal Flue (m)	9	8	6
Max Vertical Flue (m)	7.5	7.5	7.5
Seasonal Space Heating Efficiency Class	A	A	A
Seasonal Space Heating Energy Efficiency (ηs) %	94	94	94
Sound Power Level, Indoors (LWA dB)	46	46	41

2



Backlit colour screen with large text and icons

Year Guarantee†



Simple dial and button design

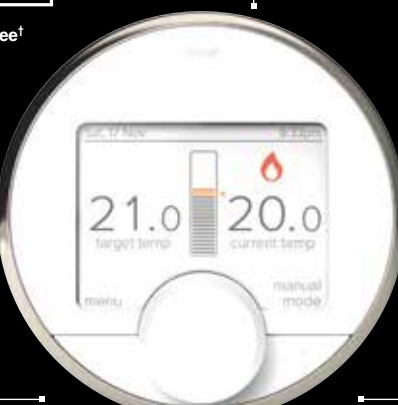

Wall mounted



Wired power no batteries



Compliments the mechanical timer



Boiler Plus compliant



Ideal OpenTherm Wired Room Thermostat

Specifically designed to work with the Instinct² by providing temperature control and boiler plus compliance in one simple device.

Boiler Plus

Boiler Plus is a set of standards implemented in England in April 2018. The boiler should have an ErP efficiency of at least 92%, and time and temperature controls should be installed. For replacement combi boilers an additional energy efficiency measure is needed, such as enhanced load compensation. The Instinct² boiler is over 92% efficiency and has built in time control with the mechanical timer. The Ideal OpenTherm Wired Room Thermostat provides temperature control and Enhanced Load Compensation. The perfect combination to comply with Boiler Plus.

Features + Benefits

- Quick and easy to install
- Easy temperature control
- Slim, modern design

Technical Specification	221527
Dimensions	96(h) x 95(w) x 35(d) mm
Weight	0.096 kg
Power Source	OpenTherm (low voltage)
Communication Protocol	OpenTherm
Level Indication for Ease of Installation	Yes
Voltage	18 – 21V dc
Wire Type	0.5-1.0mm diameter, multi-strand should be tinned
Frost Protection	Yes – default 5C
ERP Class	V
WEEE	Yes

INSTINCT®

ideal
HEATING



YEARS
OF EXCELLENCE

Customer Service

T: 01482 498660

Technical Help

T: 01482 498663

Ideal Heating, PO Box 103,
National Avenue, Kingston Upon Hull,
East Yorkshire HU5 4JN

E: enquiries@idealheating.com

www.instinctproducts.co.uk
www.idealheating.com